

HIGH POWER SOLENOID CIRCUIT

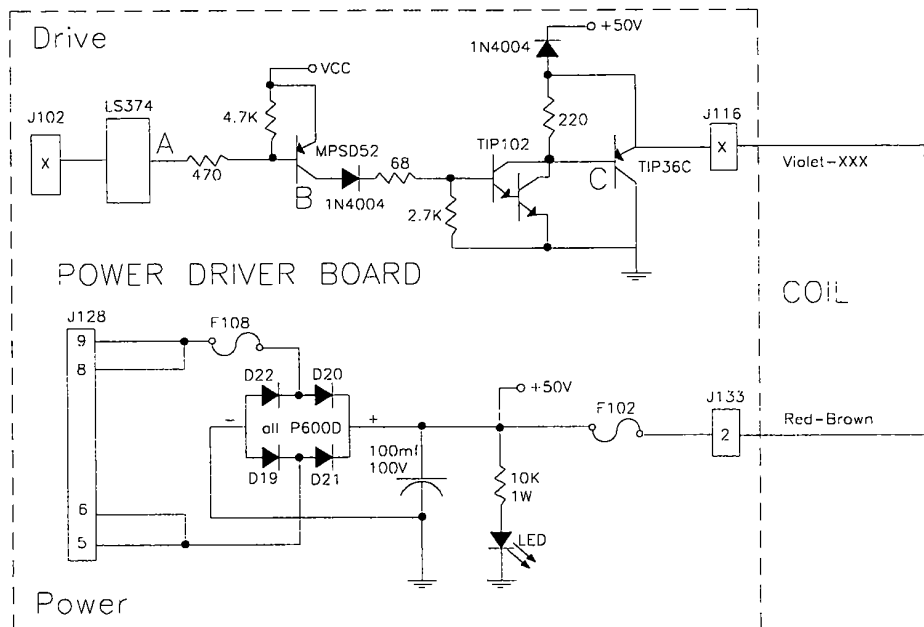

The microprocessor toggles the output of the 74LS374. When point "A" is low, point "B", the collector of the 2N5401 transistor, is high. A high at point "B" causes point "C", the collector of the TIP102 transistor and point "D", the emitter of the TIP36C transistor, to drop low. When point "D" is low, the coil is grounded through the transistor and turns on. The coil shuts off when point "A" toggles high.

LOW POWER SOLENOID CIRCUIT

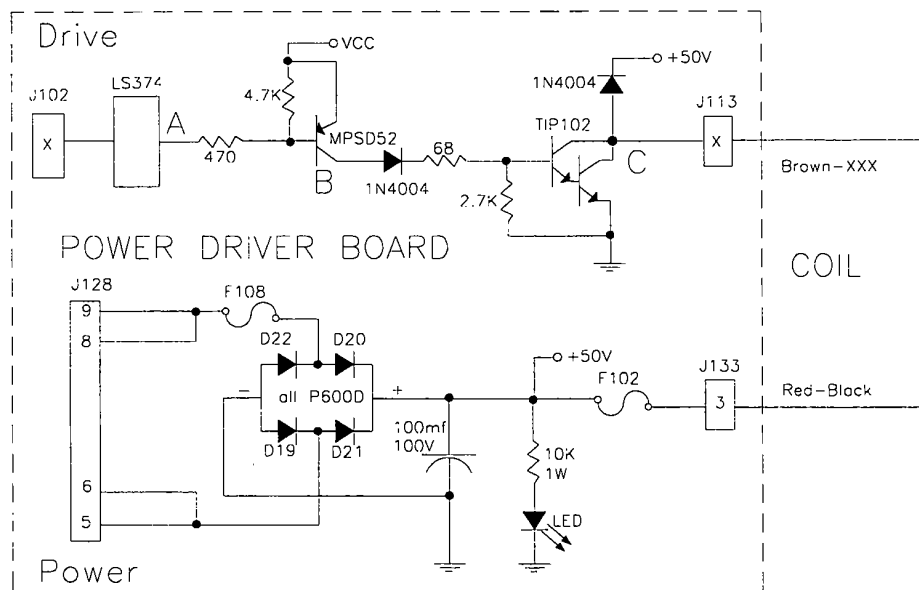

The microprocessor toggles the output of the 74LS374. When point "A" is low, point "B", the collector of the 2N5401 transistor, is high. A high at point "B" turns on the TIP102 transistor and causes point "C" to drop low. When point "C" is low the coil is grounded through the transistor and turns on. The coil shuts off when point "A" toggles high.